



High Speed Super Low Power SRAM

128K-Word By 8 Bit

CS18LV10243

■ DESCRIPTION

The CS18LV10243 is a high performance; high speed and super low power CMOS Static Random Access Memory organized as 131,072 words by 8bits and operates from a wide range of 2.7 to 3.6V supply voltage. Advanced CMOS technology and circuit techniques provide both high speed, super low power features and maximum access time of 55/ 70ns in 3.0V operation. Easy memory expansion is provided by an active LOW chip enable (/CE) and active LOW output enable (/OE).

The CS18LV10243 has an automatic power down feature, reducing the power consumption significantly when chip is deselected. The CS18LV10243 is available in JEDEC standard 32-pin sTSOP - I (8x13.4 mm), TSOP - I (8x20mm), SOP (450 mil) and PDIP (600 mil) packages.

■ FEATURES

1. Fully static operation and Tri-state output
2. TTL compatible inputs and outputs
3. Ultra low power consumption :
 - 1.5V (min) data retention
 - Low operation voltage : 2.7 ~ 3.6V ; 3mA@1MHz (Max.) operating current (Vcc = 3.0V)
4. Standby Typ. = 0.2uA, (Typical value @ Vcc = 3.0V, TA = 25 °C)
5. Standard pin configuration
 - 32 - SOP 450 mil
 - 32 - sTSOP-I - 8X13.4 mm
 - 32 - TSOP-I 8X20 mm
 - 32 - PDIP 600 mil

■ Product Family

Part No.	Operating Temp	Vcc. Range	Speed (ns)	Standby (Typ.)	Package Type
CS18LV10243CC	0~70°C	2.7~3.6	55/ 70	0.2uA (Vcc = 3.0V)	32 SOP
CS18LV10243DC					32 STSOP
CS18LV10243EC					32 TSOP (I)
CS18LV10243LC					32 PDIP
CS18LV10243CI	-40~85°C			0.5uA (Vcc= 3.0V)	32 SOP
CS18LV10243DI					32 STSOP
CS18LV10243EI					32 TSOP (I)
CS18LV10243LI					32 PDIP

Note: Green package part no, sees order information.



High Speed Super Low Power SRAM

128K-Word By 8 Bit

CS18LV10243

PIN CONFIGURATIONS

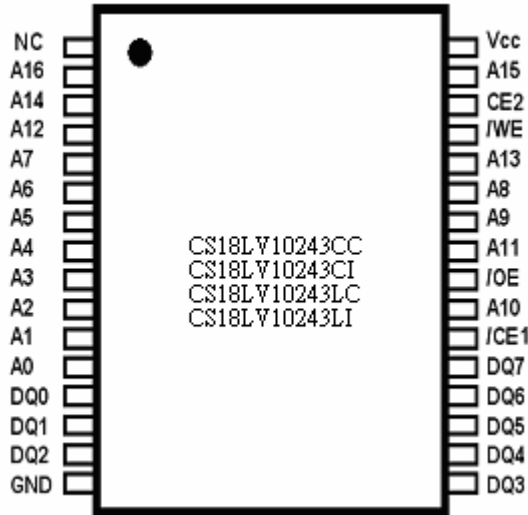

32 SOP 450 mil
32 PDIP 600 mil

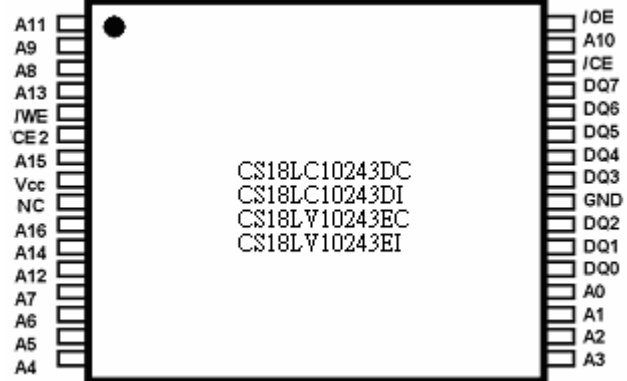

32 STSOP 8x13.4mm
32 TSOP(I) 8x20mm

BLOCK DIAGRAM

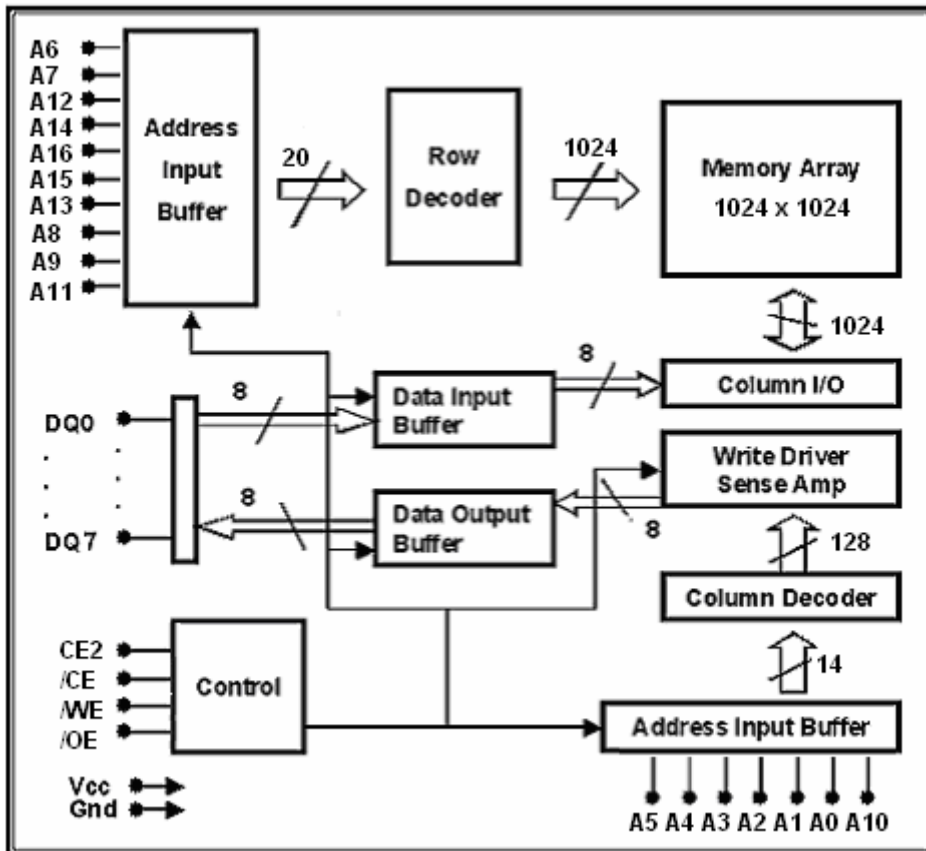



High Speed Super Low Power SRAM

128K-Word By 8 Bit

CS18LV10243

■ PIN DESCRIPTIONS

Name	Function
A0-A16 Address Input	These 17 address inputs select one of the 131,072 x 8-bit words in the RAM.
/CE Chip Enable Input CE2 Chip Enable 2 Input	/CE is active LOW and CE2 is active HIGH. Both chip enables must be active when data read from or write to the device. If either chip enable is not active, the device is deselected and is in a standby power mode. The DQ pins will be in the high impedance state when the device is deselected.
/WE Write Enable Input	The write enable input is active LOW and controls read and write operations. With the chip selected, when /WE is HIGH and /OE is LOW, output data will be present on the DQ pins; when /WE is LOW, the data present on the DQ pins will be written into the selected memory location.
/OE Output Enable Input	The output enable input is active LOW. If the output enable is active while the chip is selected and the write enable is inactive, data will be present on the DQ pins and they will be enabled. The DQ pins will be in the high impedance state when /OE is inactive.
DQ0-DQ7 Data Input/Output Ports	These 8 bi-directional ports are used to read data from or write data into the RAM.
Vcc	Power Supply
Gnd	Ground



High Speed Super Low Power SRAM

128K-Word By 8 Bit

CS18LV10243

■ TRUTH TABLE

MODE	/WE	/CE	CE2	/OE	DQ0~7	Vcc Current
Not Selected	X	H	X	X	High Z	I_{CCSB}, I_{CCSB1}
	X	X	L	X		
Output Disabled	H	L	H	H	High Z	I_{CC}
Read	H	L	H	L	D_{OUT}	I_{CC}
Write	L	L	H	X	D_{IN}	I_{CC}

■ ABSOLUTE MAXIMUM RATINGS (1)

Symbol	Parameter	Rating	Unit
V_{TERM}	Terminal Voltage with Respect to GND	-0.5 to $V_{CC}+0.5$	V
T_{BIAS}	Temperature Under Bias	-40 to +125	°C
T_{STG}	Storage Temperature	-60 to +150	°C
P_T	Power Dissipation	1.0	W
I_{OUT}	DC Output Current	20	mA

Stresses greater than those listed under ABSOLUTE MAXIMUM RATINGS may cause permanent damage to the device. This is a stress rating only and functional operation of the device at these or any other conditions above those indicated in the operational sections of this specification is not implied. Exposure to absolute maximum rating conditions for extended periods may affect reliability.

■ OPERATING RANGE

Range	Ambient Temperature	Vcc
Commercial	0~70°C	2.7V ~3.6V
Industrial	-40~85°C	2.7V ~ 3.6V

■ CAPACITANCE ⁽¹⁾ ($T_A = 25^\circ\text{C}$, $f = 1.0\text{ MHz}$)

Symbol	Parameter	Conditions	MAX.	Unit
C_{IN}	Input Capacitance	$V_{IN}=0V$	6	pF
C_{DQ}	Input/Output Capacitance	$V_{IO}=0V$	8	pF

1. This parameter is guaranteed and not tested.



High Speed Super Low Power SRAM

128K-Word By 8 Bit

CS18LV10243

■ DC ELECTRICAL CHARACTERISTICS (TA = 0 to +70°C)

Parameter Name	Parameter	Test Conduction	MIN	TYP ⁽¹⁾	MAX	Unit
V_{IL}	Guaranteed Input Low Voltage ⁽²⁾		-0.5		0.8	V
V_{IH}	Guaranteed Input High Voltage ⁽²⁾		2.0		V _{CC} +0.2	V
I_{IL}	Input Leakage Current	V _{CC} =MAX, V _{IN} =0 to V _{CC}			1	uA
I_{OL}	Output Leakage Current	V _{CC} =MAX, /CE=V _{IN} , or /OE=V _{IN} , V _{IO} =0V to V _{CC}			1	uA
V_{OL}	Output Low Voltage	V _{CC} =MAX, I _{OL} = 2mA			0.4	V
V_{OH}	Output High Voltage	V _{CC} =MIN, I _{OH} = -1mA	2.4			V
I_{CC}	Operating Power Supply Current	/CE=V _{IL} , I _{DQ} =0mA, F=F _{MAX} ⁽³⁾			30	mA
I_{CCSB}	Standby Supply - TTL	/CE=V _{IH} , I _{DQ} =0mA,			2	mA
I_{CCSB1}	Standby Current -CMOS	/CE ≥ V _{CC} -0.2V, V _{IN} ≥ V _{CC} -0.2V or V _{IN} ≤ 0.2V		0.20	5	uA

1. Typical characteristics are at TA = 25°C.
2. These are absolute values with respect to device ground and all overshoots due to system or tester notice are included.
3. Fmax = 1/t_{RC}.

■ DATA RETENTION CHARACTERISTICS (TA = 0 to +70°C)

Parameter Name	Parameter	Test Conduction	MIN	TYP ⁽¹⁾	MAX	Unit
V_{RD}	V _{CC} for Data Retention	/CE ≥ V _{CC} -0.2V, V _{IN} ≥ V _{CC} -0.2V or V _{IN} ≤ 0.2V	1.5			V
I_{CCDR}	Data Retention Current	/CE ≥ V _{CC} -0.2V, V _{IN} ≥ V _{CC} -0.2V or V _{IN} ≤ 0.2V		0.1	1.0	uA
T_{CDR}	Chip Deselect to Data Retention Time	See Retention Waveform	0			ns
t_R	Operation Recovery Time		t _{RC} ⁽²⁾			ns

1. V_{CC} = 3.0V, TA = +25°C. 2. t_{RC}= Read Cycle Time.

■ LOW V_{CC} DATA RETENTION WAVEFORM(1) (/CE1 Controlled)

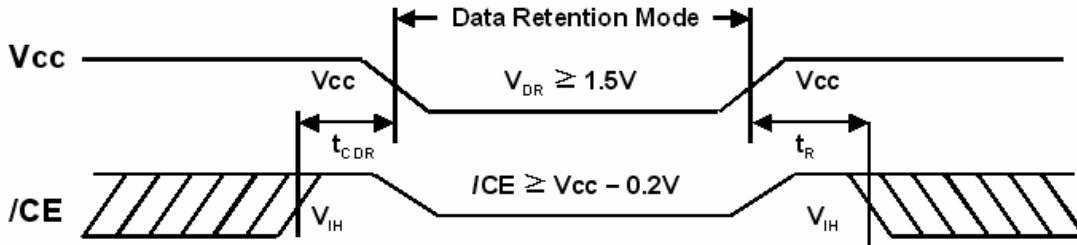

■ LOW V_{CC} DATA RETENTION WAVEFORM(2) (CE2 Controlled)

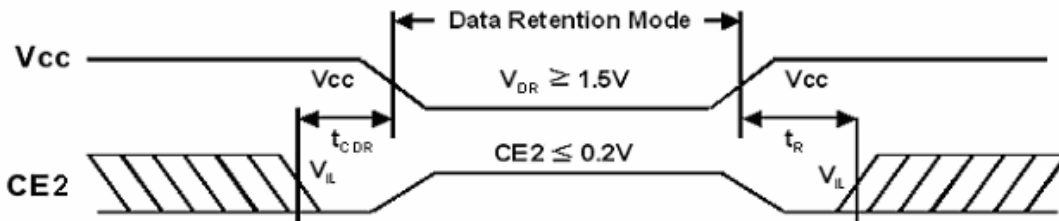

■ KEY TO SWITCHING WAVEFORMS

WAVEFORM	INPUTS	OUTPUTS
	Must be standby	Must be standby
	May change for H to L	Will be change from H to L
	May change for L to H	May change for L to H
	Don't care any change permitted	Change state unknown
	Does not apply	Center line is high impedance "OFF" state

■ AC TEST CONDITIONS

Input Pulse Levels	V _{CC} /0V
Input Rise and Fall Times	5ns
Input and Output	
Timing Reference Level	0.5V _{CC}

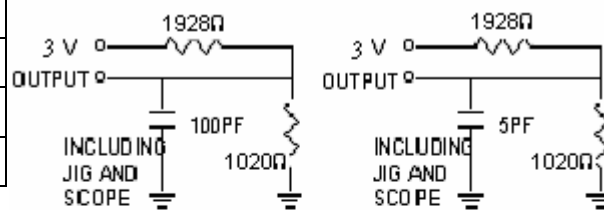

FIGURE 1A

FIGURE 1B

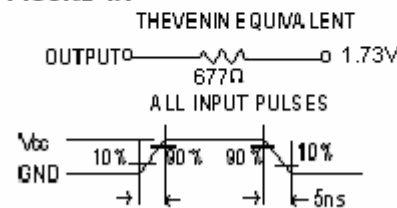

FIGURE 2



High Speed Super Low Power SRAM

128K-Word By 8 Bit

CS18LV10243

■ AC ELECTRICAL CHARACTERISTICS (TA = 0 to + 70°C , Vcc = 3.0V)

< READ CYCLE >

JEDEC Parameter Name	Parameter Name	Description	-55		-70		Unit
			MIN	MAX	MIN	MAX	
t _{AVAX}	t _{RC}	Read Cycle Time	55		70		ns
t _{AVQV}	t _{AA}	Address Access Time		55		70	ns
t _{ELQV}	t _{ACS1}	Chip Select Access Time (/CE)		55		70	ns
t _{ELQV}	t _{ACS2}	Chip Select Access Time (CE2)		55		70	ns
t _{GLQV}	t _{OE}	Output Enable to Output Valid		20		30	ns
t _{E1LQX}	t _{CLZ1}	Chip Select to Output Low Z (/CE)	10		10		ns
t _{E2LOX}	t _{CLZ2}	Chip Select to Output Low Z (CE2)	10		10		ns
t _{GLQX}	t _{OLZ}	Output Enable to Output in Low Z	5		5		ns
t _{EHQZ}	t _{CHZ1}	Chip Deselect to Output in High Z (/CE)	0	25	0	30	ns
t _{EHQZ}	t _{CHZ2}	Chip Deselect to Output in High Z (CE2)	0	25	0	30	ns
t _{GHQZ}	t _{OHZ}	Output Disable to Output in High Z	0	25	0	30	ns
t _{AXOX}	t _{OH}	Out Disable to Address Change	10		10		ns

NOTES:

1. /WE is high in read Cycle.
2. Device is continuously selected when /CE = V_{IL}.
3. Address valid prior to or coincident with CE transition low.
4. /OE = V_{IL}.
5. Transition is measured ±500mV from steady state with C_L = 5pF as shown in Figure 1B. The parameter is guaranteed but not 100% tested.

■ **SWITCHING WAVEFORMS (READ CYCLE)**

READ CYCLE (1,2,4)

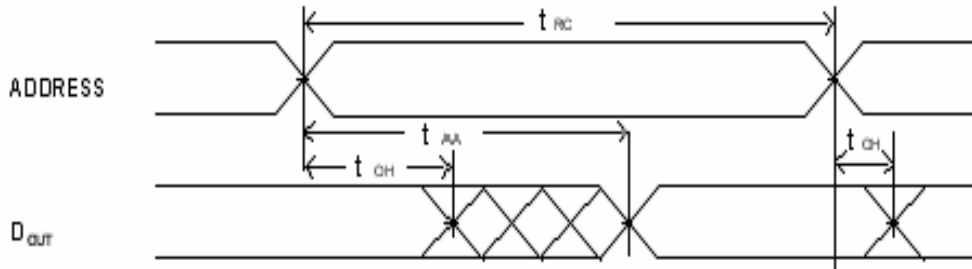

READ CYCLE (1,3,4)

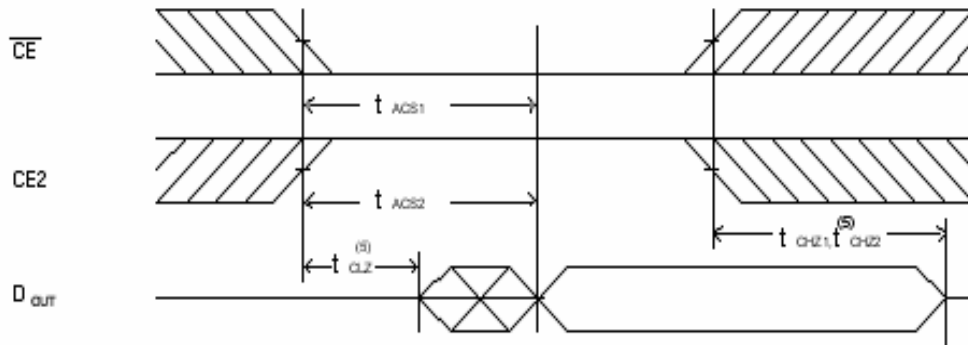

READ CYCLE (1,4)

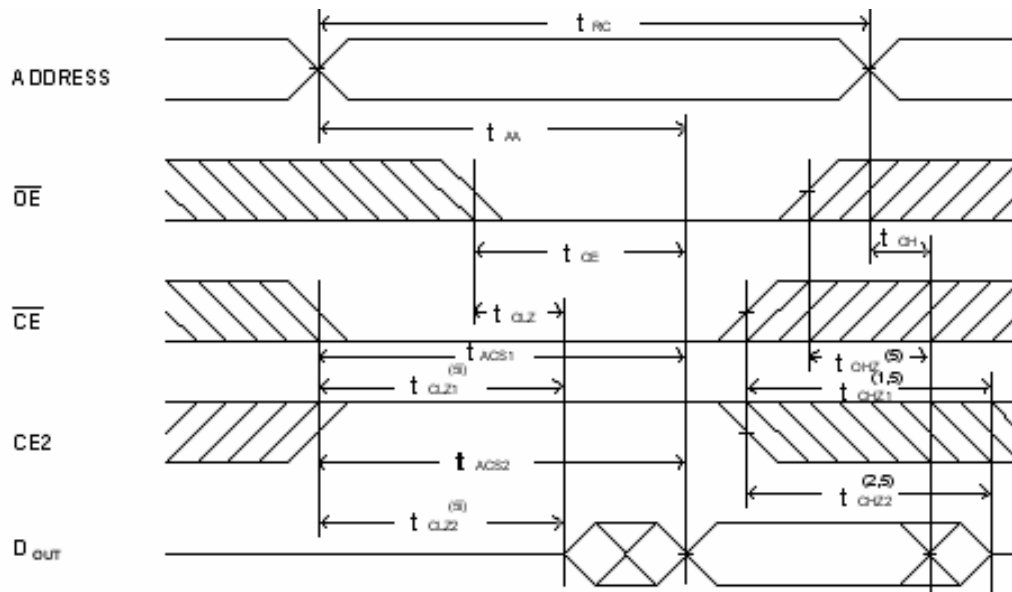



High Speed Super Low Power SRAM

128K-Word By 8 Bit

CS18LV10243

■ AC ELECTRICAL CHARACTERISTICS ($T_A = 0\sim 70^\circ\text{C}$, $V_{CC} = 3.0\text{V}$)

< WRITE CYCLE >

JEDEC Parameter Name	Parameter Name	Description	-70		Unit
			MIN	MAX	
t_{AVAX}	t_{WC}	Write Cycle Time	70		ns
t_{E1LWH}	t_{CW}	Chip Select to End of Write	70		ns
t_{AVWL}	t_{AS}	Address Setup Time	0		ns
t_{AVWH}	t_{AW}	Address Valid to End of Write	70		ns
t_{WLWH}	t_{WP}	Write Pulse Width	70		ns
t_{WHAX}	t_{WR}	Write Recovery Time (/CE, /WE)	0		ns
t_{E2LAX}	t_{WR2}	Write Recovery Time (CE2,)	0		ns
t_{WLQZ}	t_{WHZ}	Write to Output in High Z	0	25	ns
t_{DVWH}	t_{DW}	Data to Write Time Overlap	25		ns
t_{WHDX}	t_{DH}	Data Hold from Write Time	0		ns
t_{GHQZ}	t_{OHZ}	Output Disable to Output in High Z	0	25	ns
t_{WHOX}	t_{OW}	End of Write to Output Active	5		ns

■ SWITCHING WAVEFORMS (WRITE CYCLE)

WRITE CYCLE 1 (Write Enable Controlled)

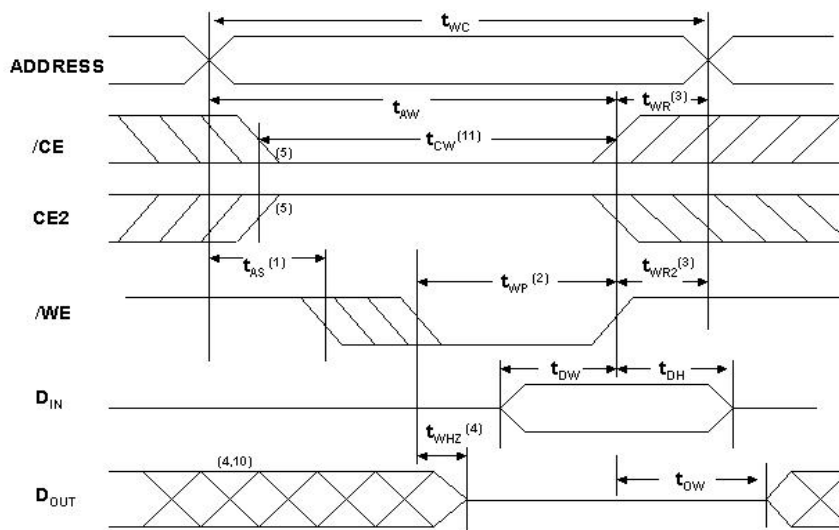



High Speed Super Low Power SRAM

128K-Word By 8 Bit

CS18LV10243

WRITE CYCLE 2 (Chip Enable Controlled)

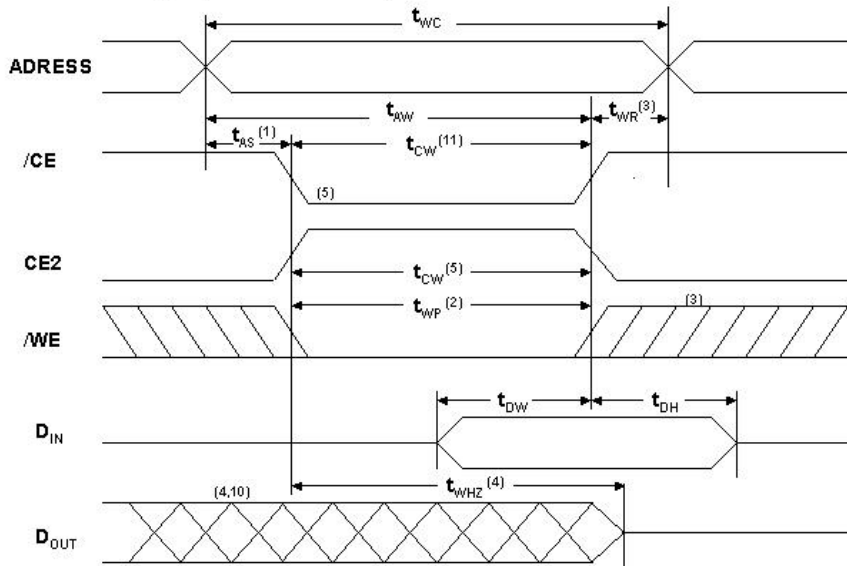

NOTES:

1. T_{AS} is measured from the address valid to the beginning of write.
2. The internal write time of the memory is defined by the overlap of $/CE$ and $/WE$ low. All signals must be active to initiate a write and any one signal can terminate a write by going inactive. The data input setup and hold timing should be referenced to the second transition edge of the signal that terminates the write.
3. T_{WR} is measured from the earlier of $/CE$ or $/WE$ going high or $CE2$ going low at the end of write cycle.
4. During this period, DQ pins are in the output state so that the input signals of opposite phase to the outputs must not be applied.
5. If the $/CE$ low transition occurs simultaneously with the $/WE$ low transitions or after the $/WE$ transition, output remain in a high impedance state.
6. $/OE$ is continuously low ($/OE = V_{IL}$).
7. D_{OUT} is the same phase of write data of this write cycle.
8. D_{OUT} is the read data of next address.
9. If $/CE$ is low during this period, DQ pins are in the output state. Then the data input signals of opposite phase to the outputs must not be applied to them.
10. Transition is measured $\pm 500mV$ from steady state with $C_L = 5pF$ as shown in Figure 1B. The parameter is guaranteed but not 100% tested.
11. T_{CW} is measured from the later of $/CE$ going low to the end of write.



High Speed Super Low Power SRAM

128K-Word By 8 Bit

CS18LV10243

■ ORDER INFORMATION

1. NON-GREEN PACKAGE:

CS18LV10243 X X - XX

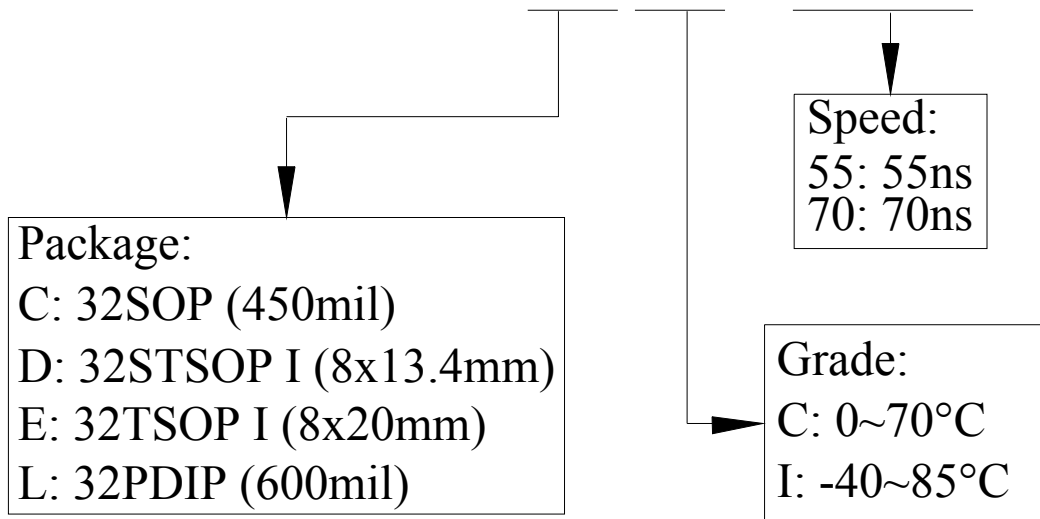

2. GREEN PACKAGE:

CS18LV10243 X X X XX

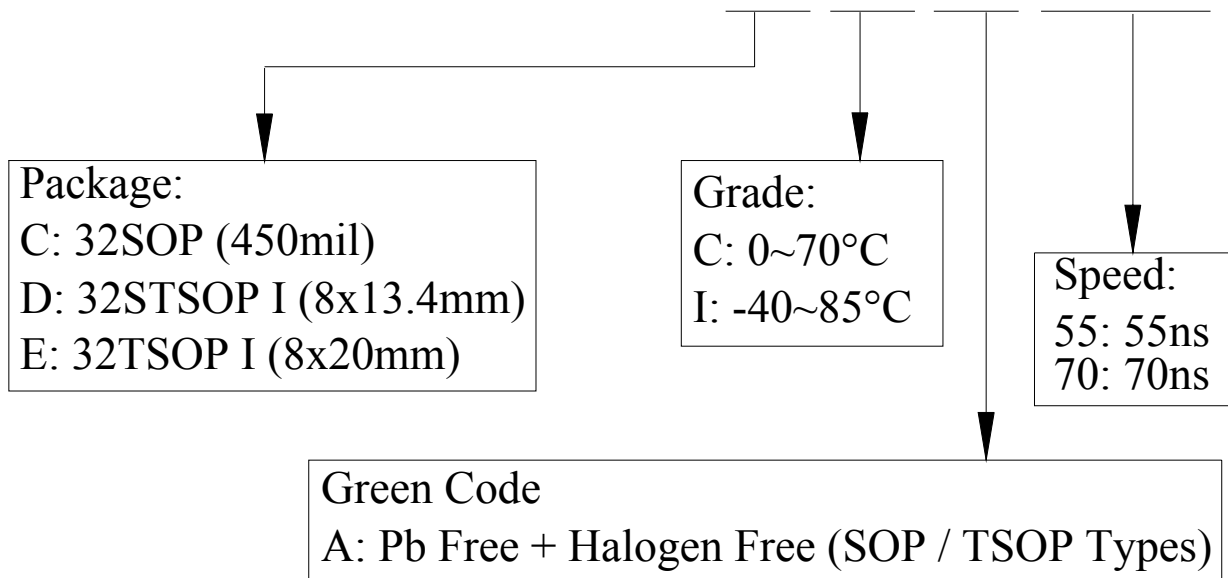



High Speed Super Low Power SRAM

128K-Word By 8 Bit

CS18LV10243

PACKAGE DIMENSIONS

- 32 pin SOP (450 mil) :

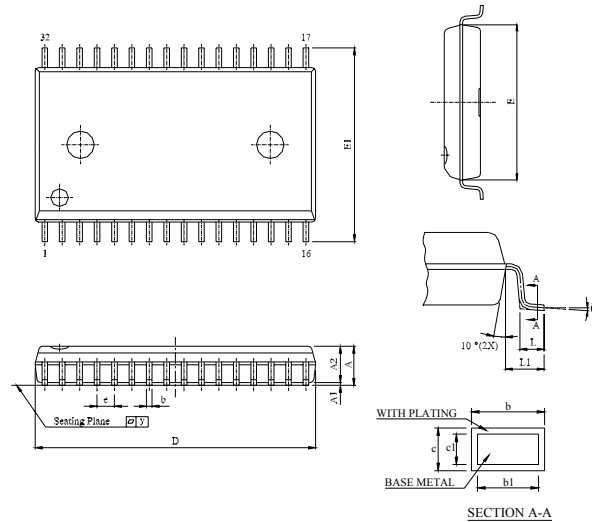

SYMBOL	A	A1	A2	b	b1	c	c1	D	E	E1	c	L	L1	y	Ø
mm	Min. 2.645	0.102	2.540	0.35	0.35	0.15	0.15	20.320	11.176	13.792	1.118	0.584	1.194	-	0°
	Nom. 2.821	0.229	2.680	-	-	-	-	20.447	11.303	14.097	1.270	0.834	1.397	-	-
	Max. 2.997	0.356	2.820	0.50	0.46	0.32	0.28	20.574	11.430	14.402	1.422	1.084	1.600	0.1	10°
inch	Min. 0.104	0.004	0.1000	0.014	0.014	0.006	0.006	0.800	0.440	0.543	0.044	0.023	0.047	-	0°
	Nom. 0.111	0.009	0.1055	-	-	-	-	0.805	0.445	0.555	0.050	0.033	0.055	-	-
	Max. 0.118	0.014	0.1110	0.020	0.018	0.012	0.011	0.810	0.450	0.567	0.056	0.043	0.063	0.004	10°

- 32 pin STSOP I (8x13.4 mm) :

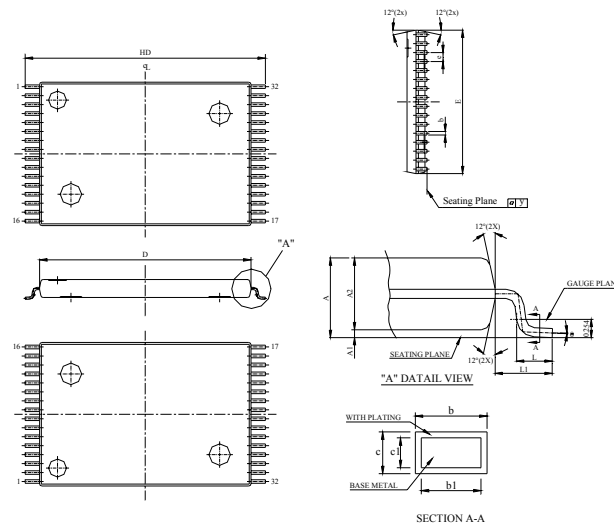

SYMBOL	A	A1	A2	b	b1	c	c1	D	E	c	HD	L	L1	y	Ø
mm	Min. 1.00	0.05	0.95	0.17	0.17	0.10	0.10	11.70	7.90	0.40	13.20	0.40	0.70	-	0°
	Nom. 1.10	0.10	1.00	0.22	0.20	-	-	11.80	8.00	0.50	13.40	0.50	0.80	-	-
	Max. 1.20	0.15	1.05	0.27	0.23	0.21	0.16	11.90	8.10	0.60	13.60	0.70	0.90	0.1	8°
inch	Min. 0.0393	0.002	0.037	0.007	0.007	0.004	0.004	0.461	0.311	0.016	0.520	0.0157	0.0275	-	0°
	Nom. 0.0433	0.004	0.039	0.009	0.008	-	-	0.465	0.315	0.020	0.528	0.0197	0.0315	-	-
	Max. 0.0473	0.006	0.041	0.011	0.009	0.008	0.006	0.469	0.319	0.024	0.536	0.0277	0.0355	0.004	8°



High Speed Super Low Power SRAM

128K-Word By 8 Bit

CS18LV10243

- 32 pin TSOP (I) (8x20 mm)

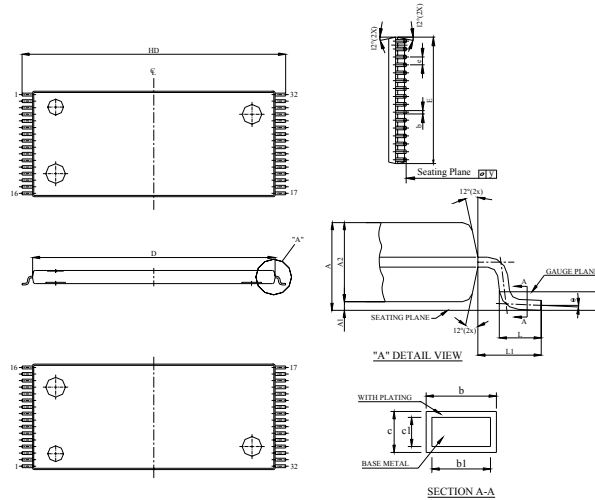

SYMBOL	A	A1	A2	b	b1	c	c1	D	E	e	HD	L	L1	y	Ø
mm	Min.	1.00	0.05	0.95	0.17	0.17	0.10	18.30	7.90	0.40	19.80	0.40	0.70	-	0°
	Nom.	1.10	0.10	1.00	0.22	0.20	-	18.40	8.00	0.50	20.00	0.50	0.80	-	-
	Max.	1.20	0.15	1.05	0.27	0.23	0.21	0.16	18.50	8.10	0.60	20.20	0.70	0.90	0.1
inch	Min.	0.0393	0.002	0.037	0.007	0.007	0.004	0.720	0.311	0.016	0.779	0.0157	0.0275	-	0°
	Nom.	0.0433	0.004	0.039	0.009	0.008	-	0.724	0.315	0.020	0.787	0.0197	0.0315	-	-
	Max.	0.0473	0.006	0.041	0.011	0.009	0.008	0.006	0.728	0.319	0.024	0.795	0.0277	0.0355	0.004

- 32 pin PDIP (600 mil)

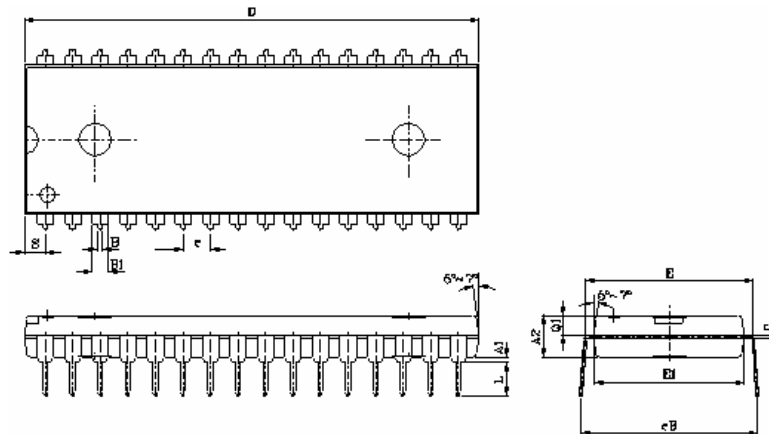

SYMBOL	A1	A2	B	B1	c	D	E	E1	e	eB	L	S	Q1
mm	Min.	0.254	3.785	0.330	1.143	0.152	41.783	14.986	13.716	16.002	3.048	1.651	1.651
	Nom.	-	3.912	0.457	1.270	0.254	41.910	15.240	13.818	16.510	3.302	1.905	1.778
	Max.	-	4.039	0.584	1.397	0.356	42.037	15.494	13.920	17.018	3.556	2.159	1.905
inch	Min.	0.010	0.149	0.013	0.045	0.006	1.645	0.590	0.540	0.630	0.120	0.065	0.065
	Nom.	-	0.154	0.018	0.050	0.010	1.650	0.600	0.544	0.650	0.130	0.075	0.070
	Max.	-	0.159	0.023	0.055	0.014	1.655	0.610	0.548	0.670	0.140	0.085	0.075